

# Improved-Concrete (IC) Typical Layout

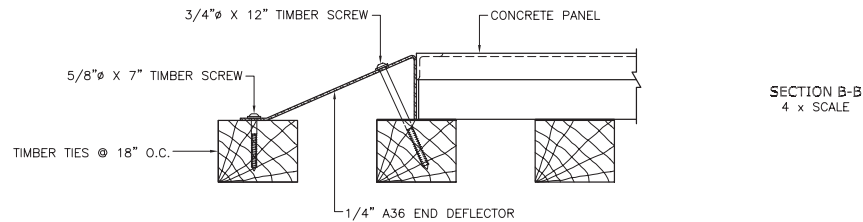
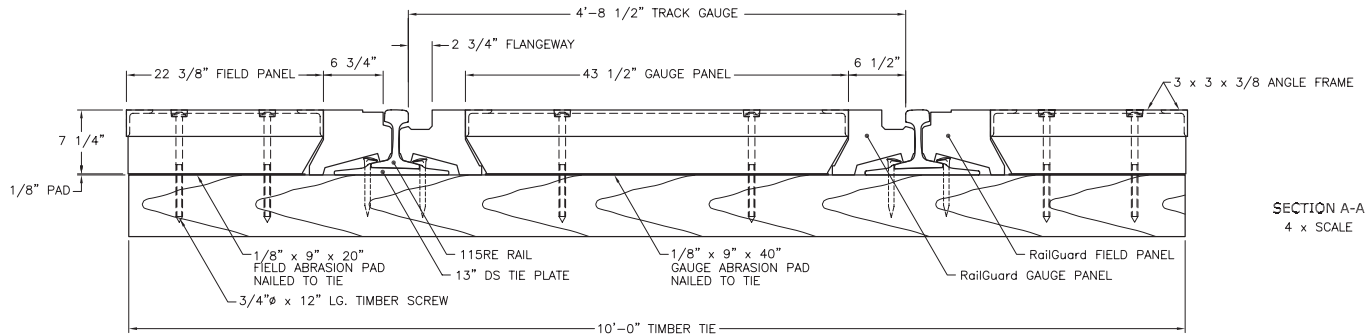
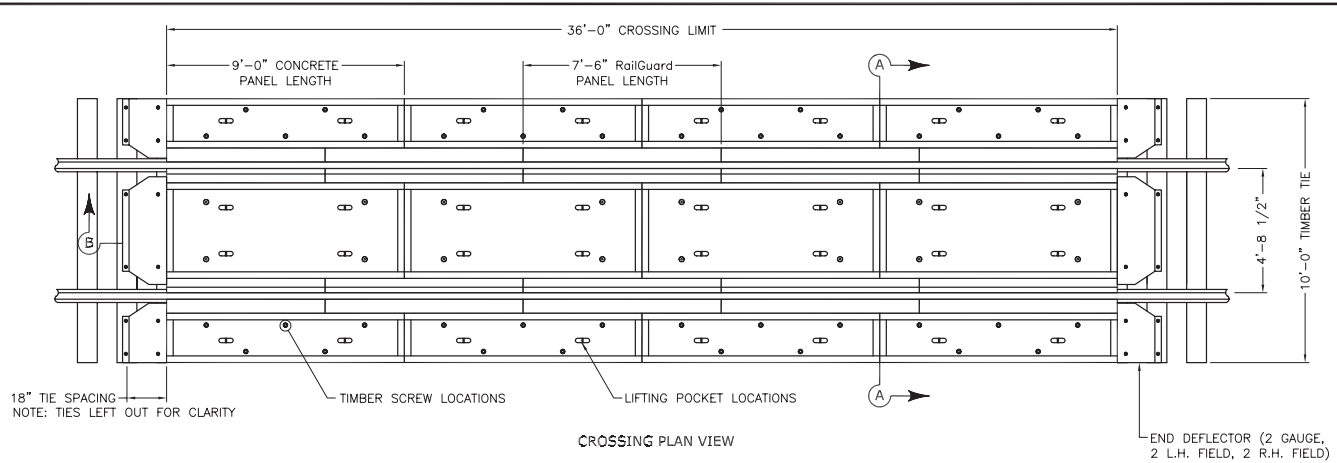

Rev. No.	Description	By	Date
<b>OMNI</b> PRODUCTS, INC. P.O. BOX 15319 PORTLAND, OREGON 97214 <b>IMPROVED CONCRETE</b> <b>GRADE CROSSING SYSTEM</b> TYPICAL PLAN AND SECTION VIEWS, 115RE RAIL, 13" DS TIE PLATES, 10' TIMBER TIES, 9' PANELS Date: 10-01-04 By: MTL Plot Scale: 1=24 Approved: Dwg. No. 10-1155-00			

THE INFORMATION CONTAINED HEREIN IS THE PROPRIETARY DATA OF OMNI PRODUCTS, INC., AND IS NOT FOR DISSEMINATION OR DISCLOSURE, IN WHOLE OR IN PART, FOR ANY PURPOSE OTHER THAN THAT FOR WHICH IT IS SUBMITTED, EXCEPT AS AUTHORIZED IN WRITING BY OMNI PRODUCTS, INC. © 2004